

UTEL 05-360

VERTICAL POLARIZED ANTENNA

5 dBi - OMNI TETRA



ELECTRICAL DATA

ANTENNA TYPE	UTEL 05-360
FREQUENCY RANGE	380 ÷ 400 MHz
IMPEDANCE	50 ohm
CONNECTOR	N f
MAX POWER	55 W
VSWR	≤ 1.5
POLARIZATION	Vertical
GAIN	5 dBi
HALFPOWERBEAMWIDTH	
Vertical plane	30°
Horizontal plane	360°
LIGHTNING PROTECTION	All metal parts DC grounded

MECHANICAL DATA

DIMENSIONS	1350 x ø 21 mm
WEIGHT	1.2 Kg
WIND SURFACE	0.03 m ²
WIND LOAD	40 N
<small>(wind speed 150Km/h)</small>	
ICING PROTECTION	Full radome
RADOME COLOUR	Grey (std.) others on request
MOUNTING	On pole (diam. 20-54 mm)
PACKING	1450 x 110 x 100 mm



RADIATION PATTERNS (mid band)

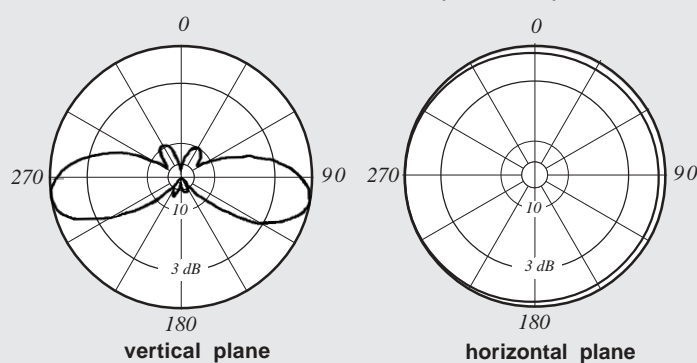

UTEL 11-360 VERTICAL POLARIZED ANTENNA 10.5 dBi - OMNI TETRA



ELECTRICAL DATA

ANTENNA TYPE	UTEL 11-360
FREQUENCY RANGE	380 ÷ 400 MHz
IMPEDANCE	50 ohm
CONNECTOR	7/16 f
MAX POWER	500 W
VSWR	≤ 1.5
POLARIZATION	Vertical
GAIN	10.5 dBi
HALFPOWERBEAMWIDTH	
Vertical plane	8°
Horizontal plane	360°
LIGHTNING PROTECTION	From the solid metal tip right down to the base of the antenna the grounding cross-section is 22 mm ² copper or more, exceeding EN 50083-1

MECHANICAL DATA

DIMENSIONS	5600 x ø 82 mm
WEIGHT	20 Kg
WIND SURFACE	0.46 m ²
WIND LOAD	500 N
<small>(wind speed 150Km/h)</small>	
ICING PROTECTION	Full radome
RADOME COLOUR	Grey (std.) others on request
MOUNTING	On pole
PACKING	6000 x 350 x 250 mm



RADIATION PATTERNS (mid band)

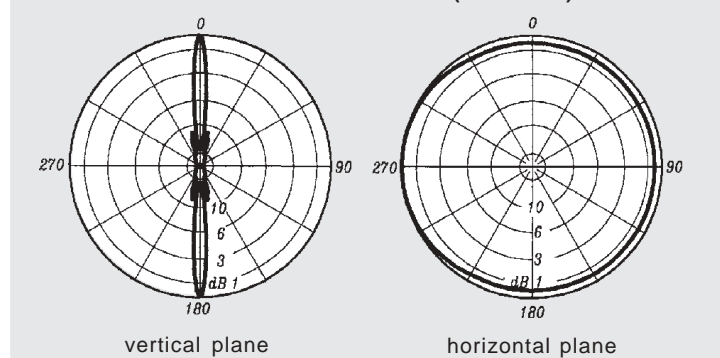

18/03/04 Subject to alteration

UTEL 13-90/C DUAL POLARIZED ANTENNA 2 x 13 dBi - 90° TETRA



ELECTRICAL DATA

ANTENNA TYPE	UTEL 13-90/C	
FREQUENCY RANGE	380 ÷ 430 MHz	430 ÷ 500 MHz
IMPEDANCE	50 ohm	
CONNECTOR	2 x 7/16 f	
MAX POWER	2 x 500 W	
VSWR	≤ 1.5	
POLARIZATION	+/- 45°	
GAIN	2 x 13 dBi	2 x 13.5 dBi
HALFPOWERBEAMWIDTH		
Vertical plane	19°	17°
Horizontal plane	88°	86°
FRONT TO BACK RATIO	≥ 20 dB (Copolar)	
ISOLATION	≥ 30 dB	
MECHANICAL DOWN TILT	Special brackets on request	
LIGHTNING PROTECTION	All metal parts DC grounded	

MECHANICAL DATA

DIMENSIONS	1997 x 317 x 193 mm	
WEIGHT	18.5 Kg	
WIND SURFACE	Front	0.61 m ²
	Side	0.38 m ²
WIND LOAD	Front	715 N
(wind speed 150Km/h)	Side	440 N
ICING PROTECTION	Full radome	
RADOME COLOUR	Grey (std.) others on request	
MOUNTING	On wall or on pole	
PACKING	2130 x 330 x 240 mm	



RADIATION PATTERNS (mid band)

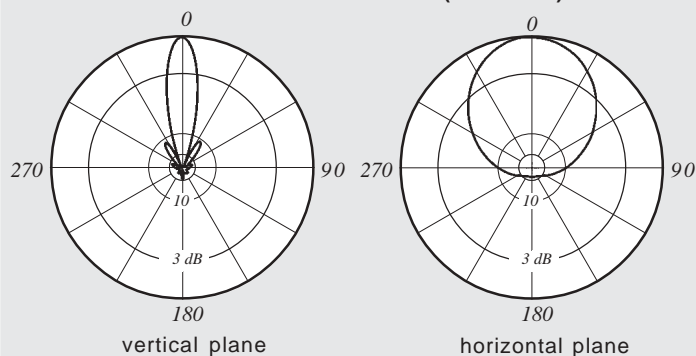

ADDITIONAL INFORMATION



ACCESSORIES

Type No.	Description	Remarks	Weight appr.	Units per antenna
738 546	1 clamp	Mast: 50 – 115 mm diameter	1.0 kg	2
850 10002	1 clamp	Mast: 110 – 220 mm diameter	2.7 kg	2
850 10003	1 clamp	Mast: 210 – 380 mm diameter	4.8 kg	2
733 677	1 clamp	Mast: 60 – 115 mm diameter	2.0 kg	2
733 678	1 clamp	Mast: 115 – 210 mm diameter	2.6 kg	2
733 679	1 clamp	Mast: 210 – 380 mm diameter	4.0 kg	2
733 680	1 clamp	Mast: 380 – 521 mm diameter	5.3 kg	2
850 10007	1 downtilt kit	Downtilt angle: 0° – 10°	4.0 kg	1

The downtilt kit can only be used in combination with the clamps type nos. 738 546, 850 10002, 850 10003.

Wall mountig: No additional mounting kit needed

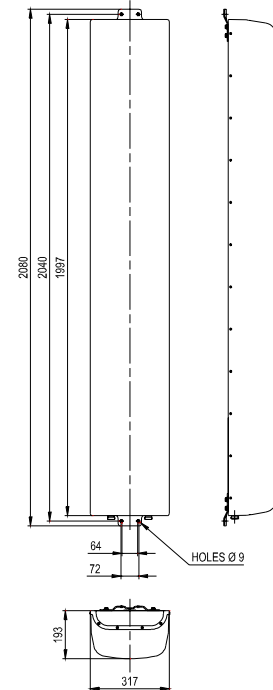

Materials:

Reflector screen: Weather-proof aluminum.
Fiberglass radome: The grey fiberglass radomes of these antennas are very stable and extraordinarily stiff. They are resistant to ultraviolet radiation and can also be painted to match their surroundings.
All screws and nuts: Stainless steel.

Grounding:

The metal parts of the antenna including the mounting kit and the inner conductor are DC grounded.

Environmental conditions: SIRA cellular antennas are designed to operate under the environmental conditions as described in ETS 300 019-1-4 class 4.1 E.

Ice protection: Due to the very sturdy antenna construction and the protection of the radiating system by the radome, the antenna remains operational even under icy conditions.

Environmental tests: SIRA antennas have passed environmental tests as recommended in ETS 300 019-2-4.



PLEASE NOTE:

As a result of more stringent legal regulations and judgements regarding product liability, we are obliged to point out certain risks that may arise when products are used under extraordinary operating conditions.

The mechanical design is based on the environmental conditions as stipulated in ETS 300 019-1-4, which include the static mechanical load imposed on an antenna by wind at maximum velocity.

Extraordinary operating conditions, such as heavy icing or exceptional dynamic stress (e.g. strain caused by oscillating support structures), may result in the breakage of an antenna or even cause it to fall to the ground. These facts must be considered during the site planning process.

The installation team must be properly qualified and also be familiar with the relevant national safety regulations.

The details given in our data sheets have to be followed carefully when installing the antennas and accessories.

The limits for the coupling torque of RF-connectors, recommended by the connector manufactures must be obeyed.